

ISOMAG 
The friendly magmeter

DATA SHEET

CS8100



CE

ISOIL 
INDUSTRIA



INDEX	
OVERALL FEATURES	3
TECHNICAL DATA	3
OVERALL DIMENSIONS WITH CONNECTORS	4
INSTALLATION RECOMMENDATIONS	5
PRESSURE LOSS	6
DISPLAY VISUALIZATION	7
ELECTRICAL CONNECTIONS	8
INPUT/OUTPUTS (CONNECTOR)	8
INPUT/OUTPUTS (CABLE)	8
OUTPUTS: SCHEMATICS	9
USER INTERFACE	10
FUNCTIONS MENU	11
HOW TO ORDER	13

TECHNICAL DATA

OVERALL FEATURES

Minimum Fluid Conductivity	<input type="checkbox"/> 20 μ S/cm
Ambient Temperature	<input type="checkbox"/> -10... +50°C / 14... +122 °F
Liquid Temperature Range	<input type="checkbox"/> -20 °C to 85 °C / -4 ...+ 185 °F
Protection Rate	<input type="checkbox"/> IP 67
Pressure Rating	<input type="checkbox"/> 1.000 kPa
Sensor Material	<input type="checkbox"/> NORYL™ + 30% of Fiber Glass
Electrodes Material	<input type="checkbox"/> Hastelloy® C276
Process Connection	<input type="checkbox"/> Male Threaded End (GAS/NPT)
Electrical connections	<input type="checkbox"/> 5 Pins Connector M12X1 Complete Of Plug <input type="checkbox"/> 5 Poles Cable Already Connected of 2 Meters Lenght
Measurement Range	<input type="checkbox"/> Bi-Directional From 50 to 2.400 l/h
Power Supply/Power Consumption	<input type="checkbox"/> 18-30VDC - 1W
Gasket Material	<input type="checkbox"/> FPM (O-Ring) <input type="checkbox"/> EPDM (Optional)
Altitude	<input type="checkbox"/> -200 m Up To 4000 m
Data Storage	<input type="checkbox"/> EEprom, Battery Backup RAM
Programming Plug In	<input type="checkbox"/> Protected USB Plug
Communications/Protocols	<input type="checkbox"/> MCP protocol Via USB Interface
Pulses/Alarm Outputs	<input type="checkbox"/> N°2 Outputs On/Off For Pulses Of Volume Or Alarms
Analog Output	<input type="checkbox"/> N°1 Output 4/20 mA
Accuracy	<input type="checkbox"/> $\pm 1,0\%$ o.r.v. + 0,5% of Full Range (From 0,5 to 5 m/s)
Diagnostic Functions	<input type="checkbox"/> Yes

OVERALL DIMENSIONS WITH CONNECTORS

Ø D	FITTINGS
12	1/2" GAS UNI338/NPT
15	3/4" GAS UNI338/NPT

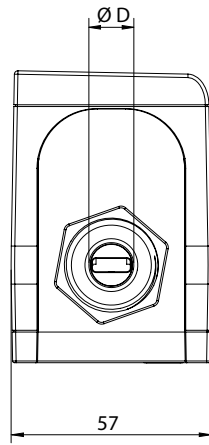
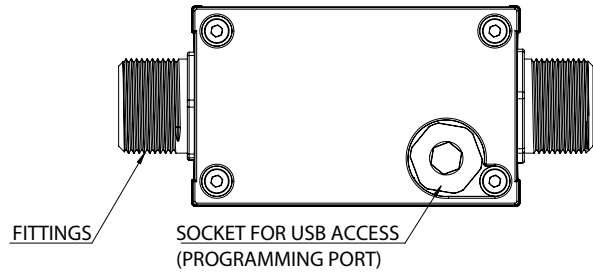

5 POLES PLUG (available only on connector version)

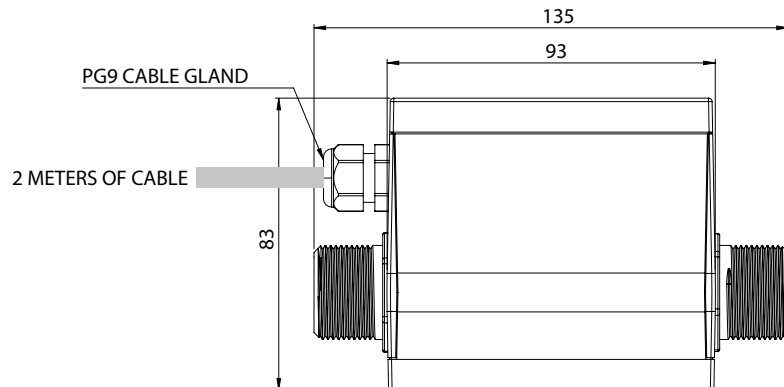
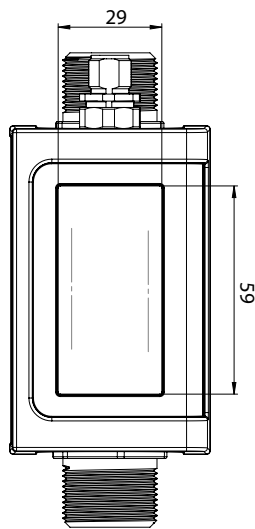
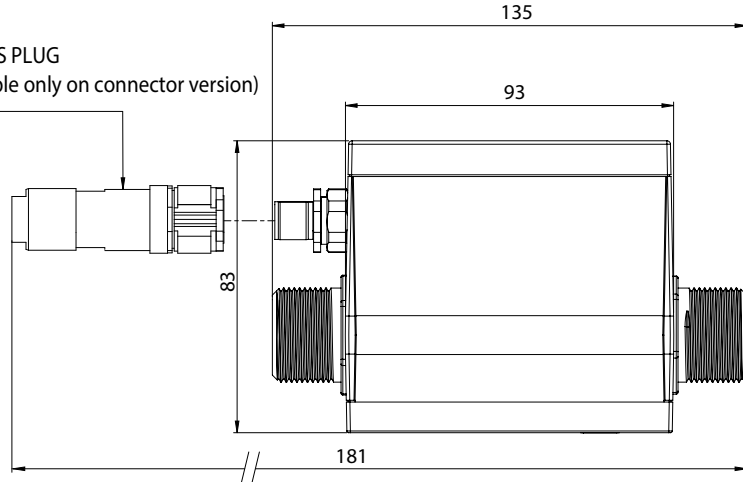

5 POLES CABLE VERSION

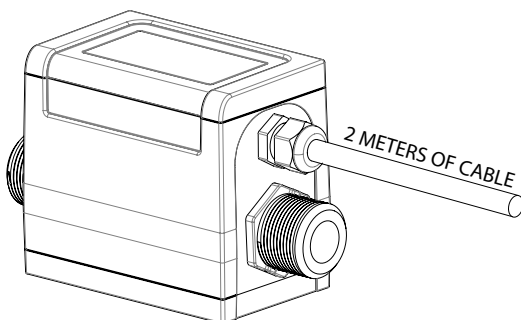

5 POLES CONNECTOR VERSION

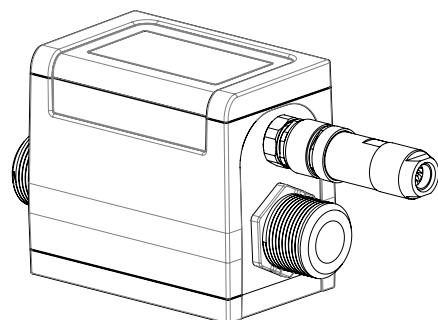

INSTALLATION RECOMMENDATIONS

In vertical installations an ascending flow is preferable. For vertical installations with descending flow direction contact the manufacturer

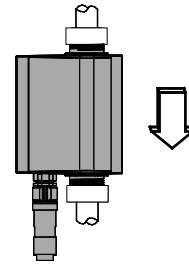
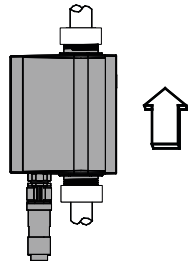

For installations in long pipe lines, please use anti vibration joints

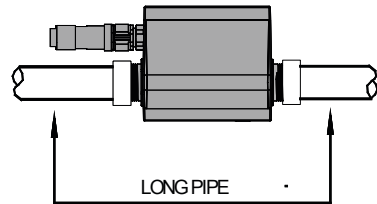
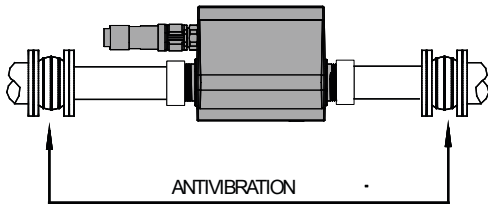

Avoid a partially empty pipe, during operation the pipe must be either completely full of liquid or completely empty

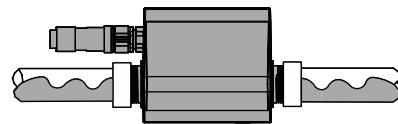

Install the sensor away from bends and hydraulic accessories

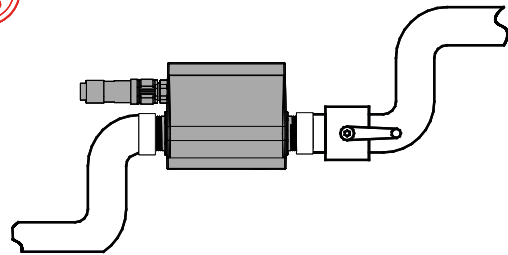
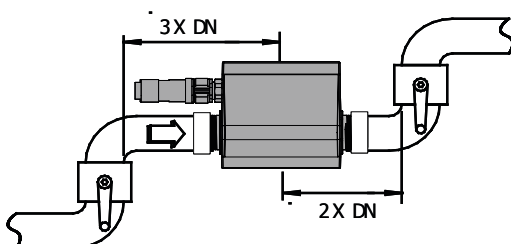

PRESSURE LOSS

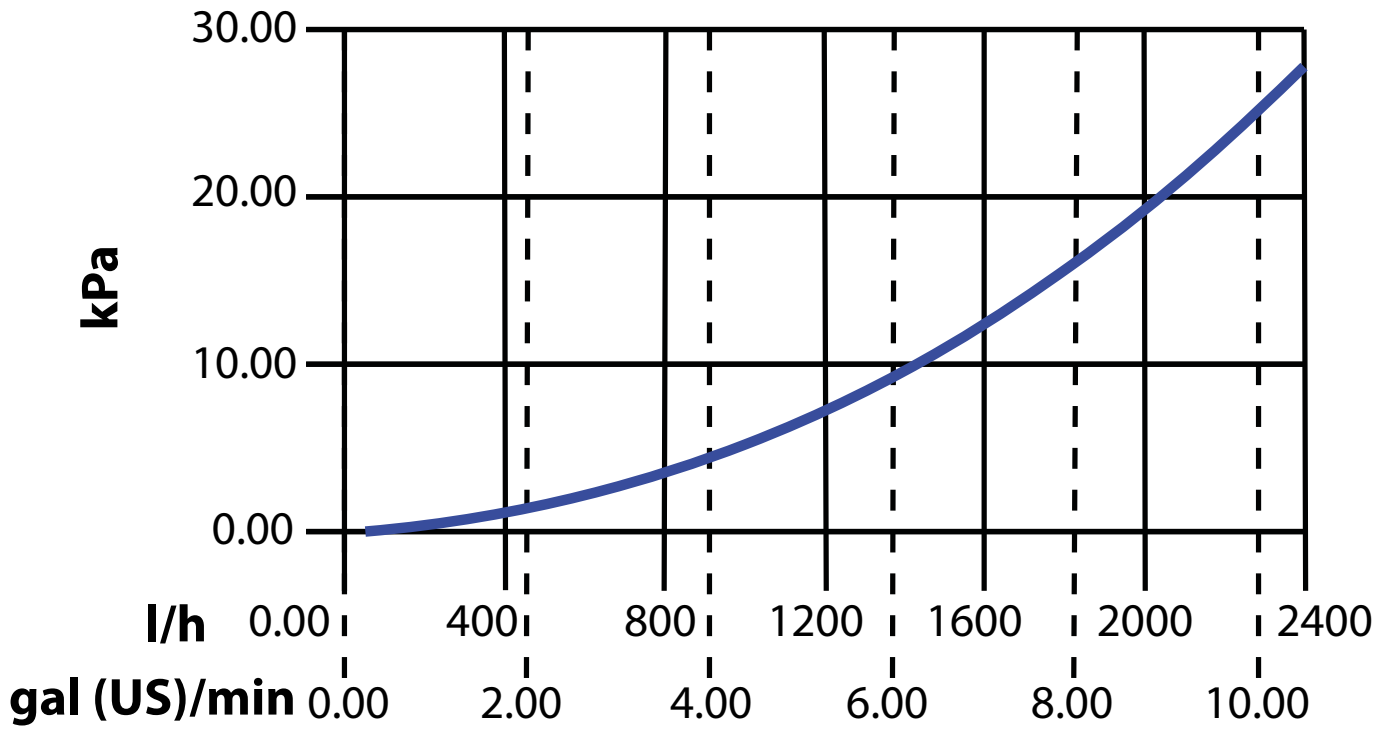

The manufacturer guarantees only English text available on our web site www.isoil.com

DISPLAY VISUALIZATION

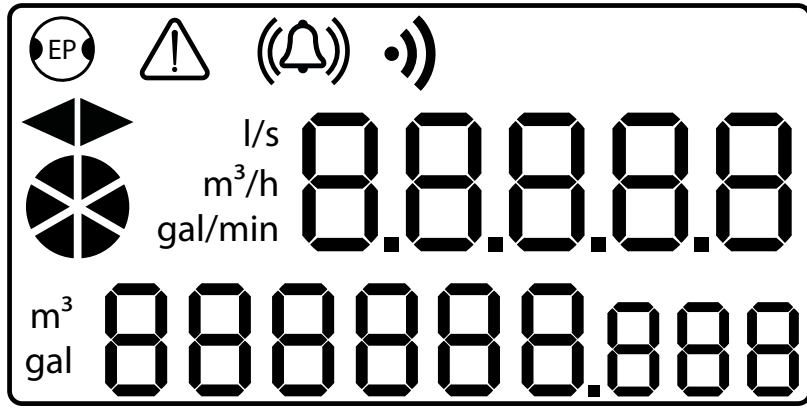

EMPTY PIPE WARNING



ALARM WARNING



XXXXXXXXXXXXXXXX



DATA TRASMISSION



FLOW DIRECTION



ACTIVE FLOW RATE

l/s
m³/h
gal/min

FLOW RATE MEASURE UNIT

m³
gal

TOTALIZER MEASURE UNIT

ELECTRICAL CONNECTIONS

INPUT/OUTPUTS (CONNECTOR)

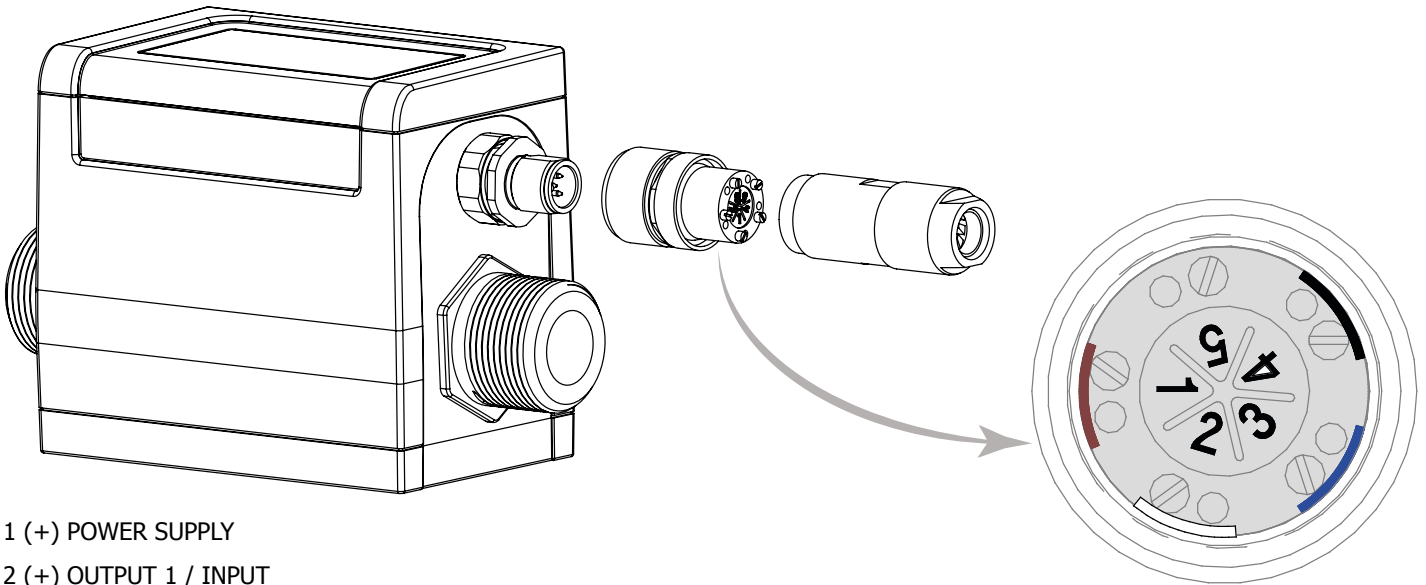

- 1 (+) POWER SUPPLY
- 2 (+) OUTPUT 1 / INPUT
- 3 (+) OUTPUT 2 (OPTIONAL)
- 4 (+) 4-20mA OUTPUT
- 5 (-) POWER SUPPLY / OUTPUTS / INPUT **(TO BE CONNECTED TO THE GROUND)**

INPUT/OUTPUTS (CABLE)

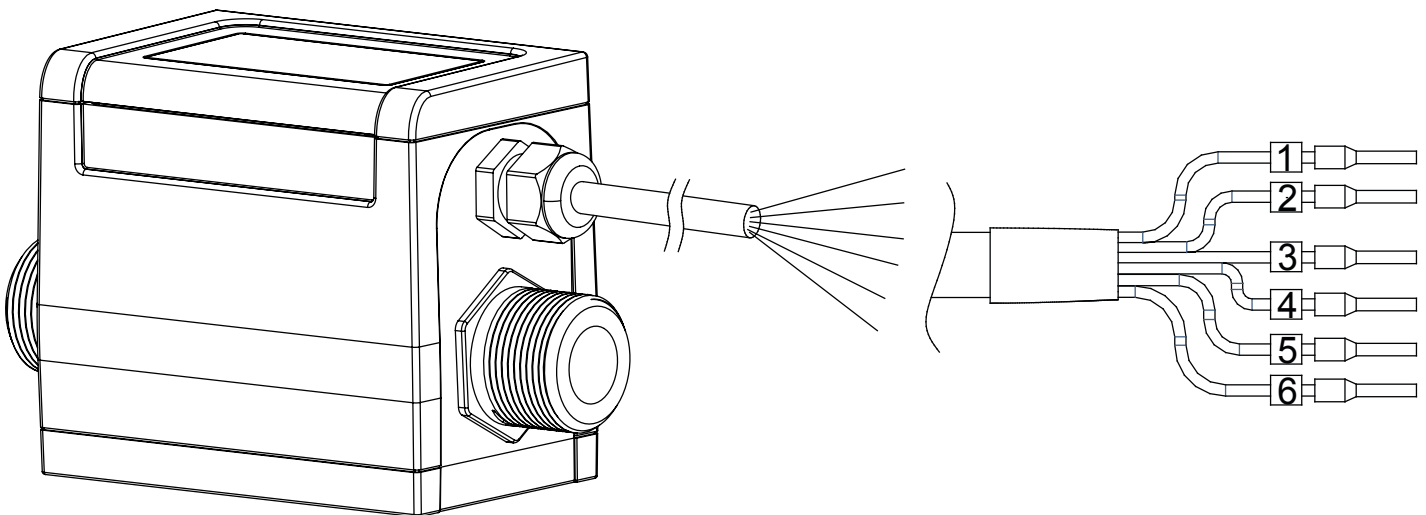

- 1 (+) POWER SUPPLY
- 2 (+) OUTPUT 1 / INPUT
- 3 (+) OUTPUT 2 (OPTIONAL)
- 4 (+) 4-20mA OUTPUT
- 5 (-) POWER SUPPLY / OUTPUTS / INPUT **(TO BE CONNECTED TO THE GROUND)**
- 6 (SH) SHIELD (CONNECT TO GROUND)

OUTPUTS: SCHEMATICS

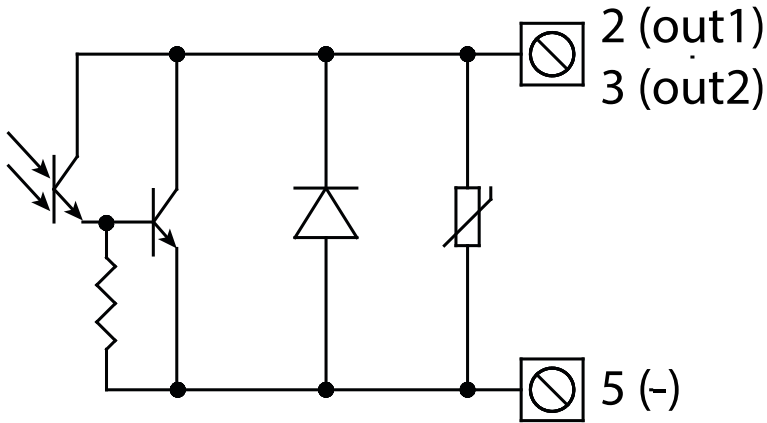

DIGITAL OUTPUTS

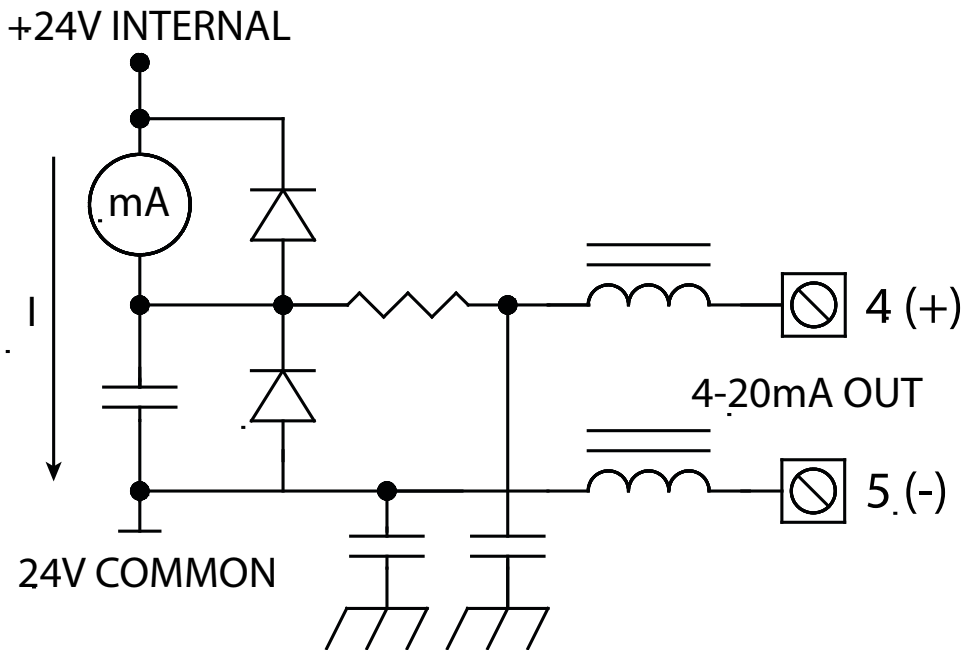

ANALOG OUTPUT

USER INTERFACE

MCP is a Windows® software that allows to set all the converter functions and personalize the menu. To use MCP interface consult the relevant user manual.



The manufacturer guarantees only English text available on our web site www.isoil.com

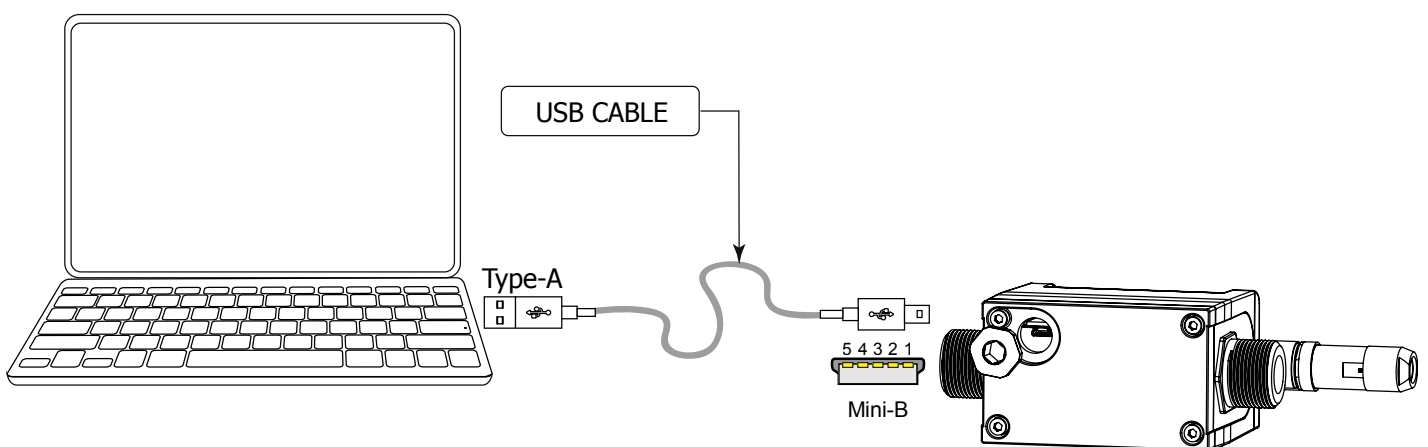

FUNCTIONS MENU

The main menu is selected from the Quick start menu by pressing enter in your key board and entering the access code. Note: Functions in grey here below are displayed only with other functions active, or with optional modules.

MAIN MENU			
1-Sensor			
SENSOR			
S.model=	010	1.1	Sensors model: Enter the first two characters of the serial number of the sensor
U.type=	METRIC	1.2	Type of measure units for sensor parameter: metric or imperial
KA=	+01.3000	1.3	Calibration data of sensor visualized on sensor's label
KZ=	+00000000	1.4	Sensor coefficient KZ (zero point)
KD=	+00000000	1.5	Sensor coefficient KD
KC=	1.000000	1.6	Sensor coefficient KC
C.Curr.=	mA 025.0	1.7	Sensor excitation current
C.Reg.PB=	005	1.8	Current regulator proportional band
C.Reg.DK=	010	1.9	Current regulator derivation constant
S.Freq.=	Hz 50	1.10	Measure sampling frequency
E.P.Detect=	ON	1.11	Enables the empty pipe detection feature
Z.max=kohm	0500	1.12	Maximum input impedance threshold
S.err.delay=	010	1.13	Signal error delay (n. sample)

MAIN MENU			
1-Sensor			
2-Units			
UNITS			
Flowrate=	METRIC	2.1	Flowrate type measure unit: metric or imperial
P1 unit=		2.2	Pulse 1 type measure unit: metric or imperial
P2 unit=		2.3	Pulse 2 type measure unit: metric or imperial
T+ unit=	METRIC	2.4	Total direct totalizer measure unit type: metric or imperial
T+ unit=	M ³	2.5	Total direct totalizer measure unit
P+ unit=	METRIC	2.6	Partial direct totalizer measure unit type: metric or imperial
P+ unit=	M ³	2.7	Partial direct totalizer measure unit
T- unit=	METRIC	2.8	Total reverse totalizer measure unit type: metric or imperial
T- unit=	M ³	2.9	Total reverse totalizer measure unit
P- unit=	METRIC	2.10	Partial reverse totalizer measure unit type: metric or imperial
P- unit=	M ³	2.11	Partial reverse totalizer measure unit

MAIN MENU			
1-Sensor			
2-Units			
3-Scales			
SCALES			
FS1=	1/5 0.0000	3.1	Valore di fondo scala per la scala 1
Frq1=	H 1000.0	3.2	Full scale frequency for channel 1 (0.1Hz-1000.0Hz)
Frq2=	H 1000.0	3.3	Full scale frequency for channel 2 (0.1Hz-1000.0Hz)
P1s1=		3.4	Pulse value on channel 1
Tp1s1=	ms	3.5	Duration of the pulse generated on channel 1
P1s2=		3.6	Pulse value on channel 2
Tp1s2=	ms	3.7	Duration of the pulse generated on channel 2

MAIN MENU			
1-Sensor			
2-Units			
3-Scales			
4-Measure			
MEASURE			
Damping=	OFF	4.1	Measure filter
Cut-off=%	00.0	4.2	Low flow zero threshold: 0-25% of full scale value
Cal.verif4=	OFF	4.3	Automatic calibration verify

MAIN MENU			
1-Sensor			
2-Units			
3-Scales			
4-Measure			
5-Alarms			
ALARMS			
Max.thr+=	% 000	5.1	Maximum value alarm set for direct flow rate
Max.thr-=	% 000	5.2	Maximum value alarm set for reverse flow rate
Min.thr+=	% 000	5.3	Minimum value alarm set for direct flow rate
Min.thr-=	% 000	5.4	Minimum value alarm set for reverse flow rate
Hysteresis=%	03	5.5	Hysteresis threshold set for the minimum and maximum flow rate alarms
mA v.alarm=%	010	5.6	Current output value in case of failure
Hz v.alarm=%	125	5.7	Frequency output value in case of alarms

```

OUTPUT:
Out1= OFF
Out2= OFF
Out mA 4.22 +/-
ALS= 1/s 0.8000
    
```

- 7.1 Output 1 functions
- 7.2 Output 2 functions
- 7.3 Choice of the function and the range of current on output
- 7.4 Full Scale value for analog out

```

9-Display
DISPLAY
Language= EN
Contrast= 5
D.rate=Hz 10
D.item= P+
Part.tot.= OFF
Neg.tot.= OFF
Quick start= OFF
    
```

- 9.1 Choice of the language: E= English, I=italian
- 9.2 Display contrast
- 9.3 Display updating frequency: 1-2-5-10 Hz
- 9.4 Second raw display item choice
- 9.5 Partial totalizer enable
- 9.6 Negative totalizer enable
- 9.7 Quick start menu visualization

```

9-Display
11-Functions
FUNCTIONS
I+ reset
P+ reset
T- reset
P- reset
Load Sens.f.def
Load Conv.f.def
Save Sens.f.def
Save Conv.f.def
Calibration
    
```

- 11.1 Execute immediate reset of total direct totalizer
- 11.2 Execute immediate reset of partial direct totalizer
- 11.3 Execute immediate reset of total reverse totalizer
- 11.4 Execute immediate reset of partial reverse totalizer
- 11.5 Load sensor factory default
- 11.6 Load converter factory default
- 11.7 Save sensor factory default values
- 11.8 Save converter factory default values
- 11.9 Execute immediate internal circuit calibration

```

9-Display
11-Functions
12-Diagnostic
DIAGNOSTIC
Self test
Display test
Flow sim.= OFF
Display measures
Disp.comm.vars
Display graphs
Firmware info
S/N= 999004
WT=0011:17:57:51
    
```

- 12.1 Self test diagnostic function
- 12.2 Function tests physical display
- 12.3 Flow rate simulation enabling
- 12.4 Display internal measured value
- 12.5 Display comm. diagnostic values
- 12.6 Display measure as graphs
- 12.7 Firmware version/revision
- 12.8 Board serial number
- 12.9 Total working time

```

9-Display
11-Functions
12-Diagnostic
13-System
SYSTEM
L1 code=*****
L2 code=*****
L3 code=*****
L4 code=*****
L5 code=*****
L6 code=*****
Restr.access=OFF
Device IP addr=
Client IP addr=
Network mask=
KT= 1.01218
KS= 1.00000
KR= 1.00000
DAC1 4mA= 02460
DAC1 20mA= 10050
FW update
    
```

- 13.1 Access level 1 code
- 13.2 Access level 2 code
- 13.3 Access level 3 code
- 13.4 Access level 4 code
- 13.5 Access level 5 code
- 13.6 Access level 6 code
- 13.7 Restricted access level
- 13.8 Device IP network address
- 13.9 Client IP network address
- 13.10 Network mask
- 13.11 Calibration coefficient KT
- 13.12 Calibration coefficient KF
- 13.13 Calibration coefficient KR
- 13.14 DAC1 out 4mA calibration point
- 13.15 DAC1 out 20mA calibration point
- 13.16 firmware update

HOW TO ORDER

CODE EXAMPLE	Connection Fittings/Max Flow Rate	
1	1	thread 1/2" GAS (UNI 338) - MAX 2.400 l/h
	2	thread 3/4" GAS (UNI 338) - MAX 2.400 l/h
	3	thread 1/2" NPT- MAX 2.400 l/h
	4	thread 3/4" NPT- MAX 2.400 l/h
Materials : body/lining /electrodes/ internal gasket/temperature		
A	A	Materials: Noryl™+ 30% Fiber Glass, electrodes in HC276®, gasket in FKM, Liquid Temperature -20/+85°C
	B	Materials: Noryl™+ 30% Fiber Glass, electrodes in HC276®, gasket in EPDM,Liquid Temperature -20/+85 °C
	Z	material: to be specified
Electronic board / Electrical Connections		
1	1	MV810 (Complete of n° 1 Freely programmable digital OUT);Electrical Connections: 5 poles connectors
	2	MV810 (Complete of n° 1 Freely programmable digital OUT);Electrical Connections: 2 meters of N° 5 poles cable ALREADY CONNECTED
ANALOG Output		
A	A	without Analog Out
	B	with Analog Out
DIGITAL Output		
1	1	without Additional Digital OUT
	2	with n° 1 Additional Digital OUT



CS8100-1A1A1 (Complete code example for order)

ISOIL INDUSTRIA S.p.A.

HEAD OFFICE	SERVICE
Via Fratelli Gracchi, 27 20092 Cinisello Balsamo (MI) Tel +39 02 66027.1 Fax +39 02 6123202 vendite@isoil.it	isomagservice@isoil.it

If you want to find the complete list of our distributors access at the following link:
http://www.isoil.com/u_vendita.asp



Due to the constant technical development and improvement of its products, the manufacturer reserves the right to make changes and/or modify the information contained in this document without notice.